

CNC machines

Overview

CNC machines

5-4

ICP series



CNC machines

5-6

ICV series



CNC machine

5-8

EuroMod



CNC machine

5-10

FlatCom M



CNC machine

5-12

FlatCom L



CNC machine

5-14

FlatCom XL

Flatbed and
portal units

5-16



CNC machines

Overview

Accessories

5-18

Spindle motors

5-19

iSA 500 with manual tool change
 iSA 750 with manual tool change
 iSA 1500 with manual tool change
 iSA 1500 L with manual tool change
 iSA 900 with automatic tool change
 iSA 2200 with automatic tool change
 iSA 3600 with automatic tool change
 iSA 1500 W with automatic tool change
 UFM 500 / UFM 1050

CoolMin tool cooling system

5-28

Tool changing stations

5-30

Frequency converter

5-31

Length measuring sensor
 Motor leads
 Vacuum cleaning

Collets

5-32

Tool holders

6-axis robots

5-33

Vacuum clamping plates

5-34

ROBOTICS

5-32

IWH F-1 wafer handling robots
 IWH F-2 wafer handling robots
 IWH F-3 wafer handling robots
 IWH F-5 vacuum robots
 Vacuum elevator
 Linear Track
 End effectors
 Pre-aligners
 Controller and accessories



CNC machine

with step motor drive

ICP



ICP 4030 with hood open

Dimensioned drawings

	ICP 3020	ICP 4030
Width W [mm]	610	780
Depth D [mm]	650	850
Height H1 [mm]	715	810
Height H2 [mm]	670	770
Height H3 [mm]	1030	1203
Height H4 [mm]	1080	1250

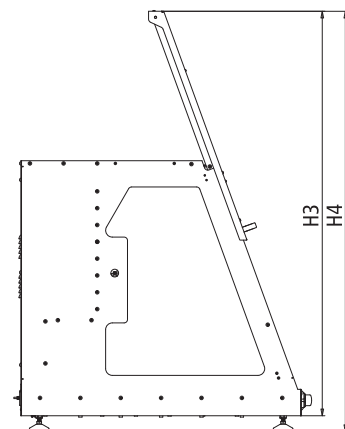
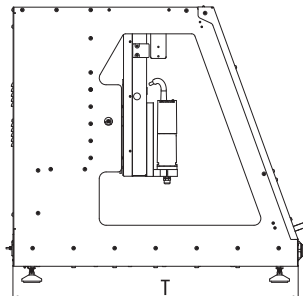
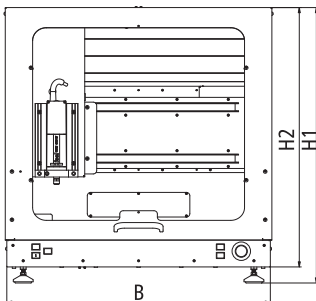

CNC machine

with step motor drive

ICP

General

CNC machines in the ICP series have been developed from the proven CPM series. By introducing a sliding door, the machines can now be operated in a sitting position which, inter alia, leads to shorter cycle times when opening the hood. The chassis is completely bolted instead of being welded like its predecessors. This produces higher precision when building the machine and makes servicing easier. In addition, it was possible to optimise the resonance and vibration behaviour and therefore lower noise build-up has been achieved.

Technical specification

	ICP 3020	ICP 4030
Traverse path X/Y/Z [mm]	300 × 200 × 90	400 × 300 × 140
Clamping table surface W × D [mm]	500 × 250	600 × 375
Throughput [mm]	115	170
Dimensions W × D × H [mm]	610 × 650 × 715	780 × 850 × 810
Guides	Linear units with precision steel shafts and recirculating ball slots, clearance free adjustable	
Process speed X/Y/Z [mm/s]	100	
Repeatability [mm]	± 0.02	
Drive motors	Stepper motors	
Drive elements X/Y/Z	Ball screw drives 16 × 10/16 × 10/16 × 4 mm Clearance free adjustable (optional: 16 × 4 mm in X/Y/Z)	
Controller	iMC-P step controller with 4 final stages 48V/4.2A and 500W power supply unit with processor board	
Operation	Function keys and emergency shutdown	
Software	WinRemote (optional: ProNC, isy 2.5 PLUS)	
Weight [kg]	appr. 102	appr. 120
Part no.:	280210 7406 *	280220 7405 *

* The deliverables include an accompanying pack with mechanical accessories (inter alia Hand lever clamping device, stop rails Triangle wrench, open jaw wrench, hook wrench, Allen key, one 6-socket bench extension, connection lead, power lead)

Accessories

280220 9012	Cooling/spray device for ICP 3020/4030
280120 9010	Length measuring button for ICP 3020/4030
280120 9004	Workspace lighting for ICP 3020/4030
420003 0500	Milling motor UFM 500, 500 W, 11,000...25,000 r.p.m.
280110 9001	Suction device for UFM 500
Z13-337030	isy-CAM 2.5 PLUS
Z11-333500	ProNC software
310704 1631	iSA 500 spindle motor up to 30,000 rpm, 500 W, with frequency converter, CoolMin tool cooling system, ER 11 clamping ring and motor lead (only ICP 4030)
310707 1631	iSA 750 spindle motor up to 24,000 rpm, 750 W, with frequency converter, CoolMin tool cooling system, ER 16 clamping ring and motor lead (only ICP 4030)
280210 9001	Suction device for iSA 500 / 750
280000 0046	Fixing plate for main spindle drive iSA 500 / 750
290055	Vice 1 (W 130 × H 45 × L 152 mm)
290056	Vice 2 (W 180 × H 75 × L 215 mm)

CNC machine

with servo motor drive

ICV 4030

Control unit
... with integrated
control computer.

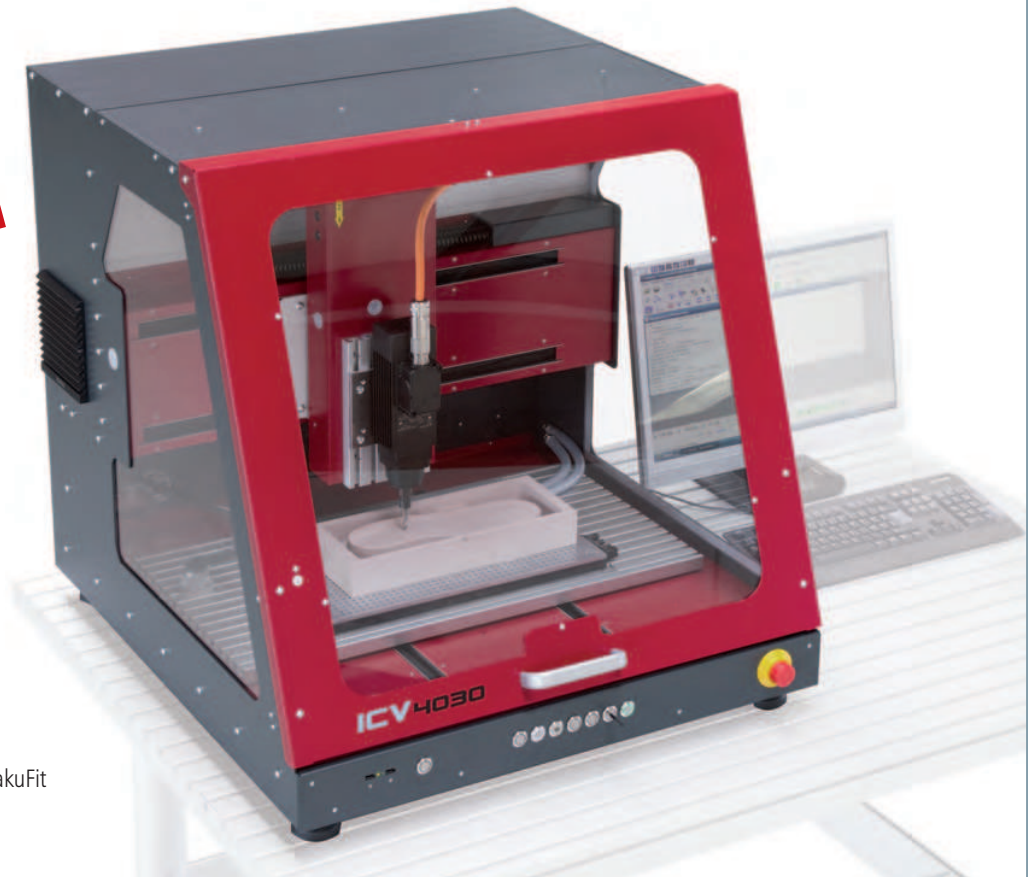

ICV 4030-F
with optional
Vacuum clamping system VakuFit

Dimensioned drawings

	ICV 4030
Width W [mm]	780
Depth D [mm]	835
Height H1 [mm]	806
Height H2 [mm]	765
Height H3 [mm]	1203
Height H4 [mm]	1250

machine bench
W 1500 D1000 H 750
Part no. 248550 0013

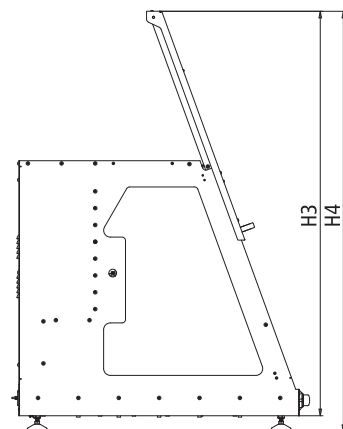
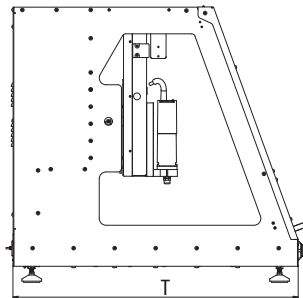
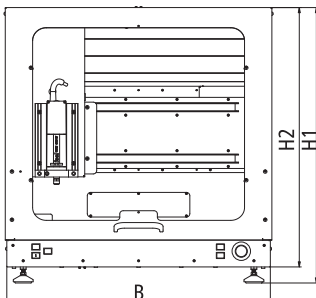

CNC machine

with step motor drive

ICP

General

CNC machines in the ICP series have been developed from the proven CPM series. By introducing a sliding door, the machines can now be operated in a sitting position which, inter alia, leads to shorter cycle times when opening the hood. The chassis is completely bolted instead of being welded like its predecessors. This produces higher precision when building the machine and makes servicing easier. In addition, it was possible to optimise the resonance and vibration behaviour and therefore lower noise build-up has been achieved.

Technical specification

	ICP 3020	ICP 4030
Traverse path X/Y/Z [mm]	300 × 200 × 90	400 × 300 × 140
Clamping table surface W × D [mm]	500 × 250	600 × 375
Throughput [mm]	115	170
Dimensions W × D × H [mm]	610 × 650 × 715	780 × 850 × 810
Guides	Linear units with precision steel shafts and recirculating ball slots, clearance free adjustable	
Process speed X/Y/Z [mm/s]	100 (for Ball screw drives 16x10) 60 (for Ball screw drives 16x4)	
Repeatability [mm]	± 0.02	
Drive motors	Stepper motors	
Drive elements X/Y/Z	Ball screw drives 16 × 10/16 × 10/16 × 10 mm Clearance free adjustable (optional: 16 × 4 mm in X/Y/Z)	
Controller	iMC-P step controller with 4 final stages 48V/4.2A and 500W power supply unit with processor board	
Operation	Function keys and emergency shutdown	
Software	WinRemote (optional: ProNC, isy 2.5 PLUS)	
Weight [kg]	appr. 102	appr. 120
Part no.:	280210 7406 *	280220 7405 *

* The deliverables include an accompanying pack with mechanical accessories (inter alia Hand lever clamping device, stop rails Triangle wrench, open jaw wrench, hook wrench, Allen key, one 6-socket bench extension, connection lead, power lead)

Accessories

280220 9012	Cooling/spray device for ICP 3020/4030
280120 9010	Length measuring button for ICP 3020/4030
280120 9004	Workspace lighting for ICP 3020/4030
420003 0500	Milling motor UFM 500, 500 W, 11,000...25,000 r.p.m.
280110 9001	Suction device for UFM 500
Z13-337030	isy-CAM 2.5 PLUS
Z11-333500	ProNC software
310704 1631	iSA 500 spindle motor up to 30,000 rpm, 500 W, with frequency converter, CoolMin tool cooling system, ER 11 clamping ring and motor lead (only ICP 4030)
310707 1631	iSA 750 spindle motor up to 24,000 rpm, 750 W, with frequency converter, CoolMin tool cooling system, ER 16 clamping ring and motor lead (only ICP 4030)
280210 9001	Suction device for iSA 500 / 750
280000 0046	Fixing plate for main spindle drive iSA 500 / 750
290055	Vice 1 (W 130 × H 45 × L 152 mm)
290056	Vice 2 (W 180 × H 75 × L 215 mm)

CNC machine

with servo motor drive

EUROMod[®]

EuroMod MP 45
with closed sliding door

Technical specification

	<i>EuroMod[®]</i> MP 30	<i>EuroMod[®]</i> MP 45	<i>EuroMod[®]</i> MP 65
Processing areas X/Y/Z [mm] *	650/300/250	650/450/250	1000/650/250
Bench clamping area W × D [mm]	900x350	900x500	1200x700
Gap [mm] *	350		
Dimensions WxDxH [mm]	1160x800x1960	1160x1110x1960	1480x1510x1960
Processing speed X/Y/Z	max. 250 mm/s		
Repeat accuracy [mm]	± 0.02		
Drive motors	Servo motors		
Drive elements X/Y/Z	Recirculating ball drive, adjustable for no play		
Controller	iMD CAN controller with 3 drive controllers, expandable to 12 axes (max. 6 interpolated & 6 handling axes), PC, I/O module, safety circuit with rest state monitoring, power supply unit 48V/1000 W		
Operation	19" CNC control panel with touch screen, keyboard and mouse		
Weight (kg)	approx. 275	approx. 300	approx. 400
Software	Windows, WinRemote (optional: ProNC, isy 2.5 PLUS)		
Connection values	230 V, 16 A		
Part no.	275133 53655	275143 53655	275153 53655

* without mounted components on the axes.

CNC machine

with servo motor drive

EUROMOD[®]

systems

General note

The choice of the ideal CNC machine for you should focus both on the clamping area for the workpiece, materials or plates to be machined and on the strategy or difficulties of the machining. In principal, all machines are perfectly suited for machining light metals, non-ferrous metals, plastics and wood . Extensive range of accessories for all our CNC machines to order (see Page 5-18 et seq.).

Options

- PC control console with free PCI plug-ins (for use by external PCI hardware)
- Stainless steel keyboard
- Safety light curtain
- Milling and engraving spindles
- SK11/SK20 automatic tool change stations
- Minimum quantity lubrication or CoolMin cooling system
- Vacuum clamping benches
- Suction device
- 4th axis e. g. RDH series installation
- pneumatic sliding door
- closed hood attachment

Setup

- Portal: fixed, bench: moveable

Dimensioned drawings/dimensions

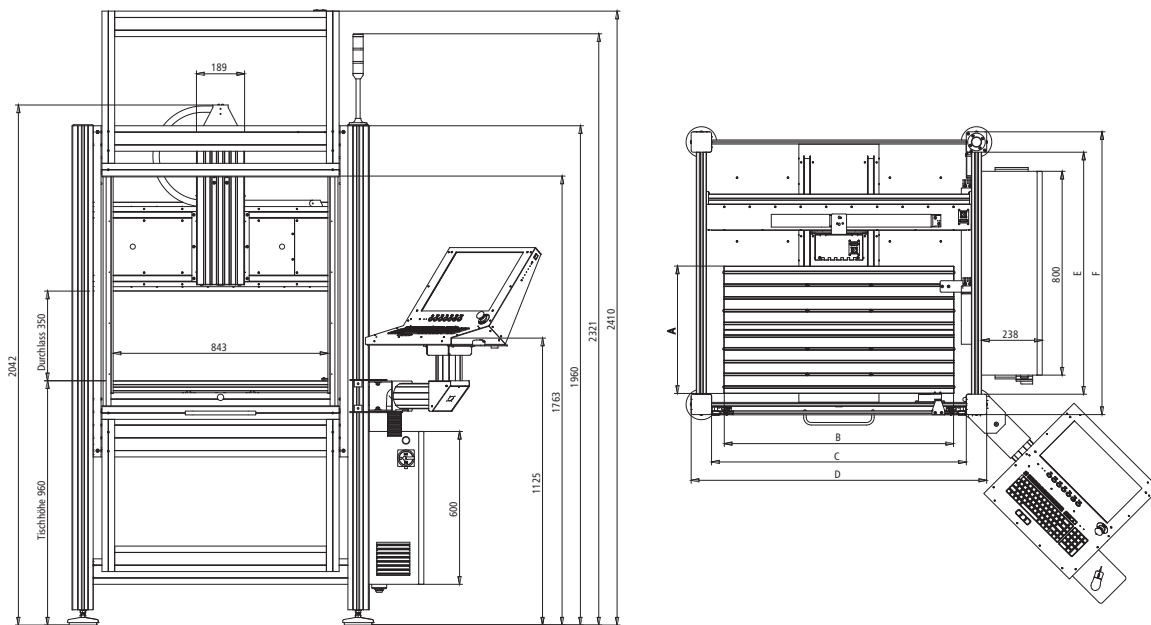

	A	B	C	D	E	F
EuroMod MP30	350	900	1000	1160	640	800
EuroMod MP45	500	900	1000	1160	950	1110
EuroMod MP65	700	1200	1200	1480	1350	1510

We reserve the right to make technical changes.

CNC machine

with servo motor drive

FLATCom®
M series



FlatCom M 30

with open hood and options:
spindle motor, tool changer, VakuFit vacuum
clamping plate, length measuring key, CoolMin
tool cooling, CNC joystick

Technical specification

	FLATCom® M 20	FLATCom® M30	FLATCom® M40	FLATCom® M50
Processing areas X/Y [mm] *	700/600	700/900	1200/900	1200/1400
Z lift [mm]	150 (optional 250, in each case without processing unit)			
Bench clamping area W × D [mm]	750x750	750x1000	1250x1000	1250x1500
Z gap [mm] *	200 (optional 300, in each case without processing unit)			
Dimensions WxDxH [mm]**	1420x1150x1870	1420x1450x1870	1920x1450x1870	1920x1950x1870
Processing speed X/Y/Z	max. 250 mm/s			
Repeat accuracy [mm]	± 0.02			
Drive motors	Servo motors			
Drive elements X/Y/Z	Recirculating ball drive, adjustable for no play			
Controller	iMD CAN controller with 3 drive controllers, expandable to 12 axes (max. 6 interpolated & 6 handling axes), PC, I/O module, safety circuit with rest state monitoring, power supply unit 48 V / 1000 W			
Operation	19" CNC control panel with touch screen, keyboard and mouse			
Weight (kg)	approx. 300	approx. 340	approx. 450	approx. 525
Software	Windows, WinRemote (optional: ProNC, isy 2.5 PLUS)			
Connection values	230 V, 16 A		400 V, 16 A	
Part no.	275023 52455 **	275033 52455 **	275043 52455 **	275053 52455 **

* without mounted components on the axes.

** with switchgear cabinet and hood

CNC machine

with servo motor drive

FLATCom[®]
M series

General note

The choice of the ideal CNC machine for you should focus both on the clamping area for the workpiece, materials or plates to be machined and on the strategy or difficulties of the machining. In principal, all machines are perfectly suited for machining light metals, non-ferrous metals, plastics and wood. Extensive range of accessories for all our CNC machines to order (see Page 5-18 et seq.).

Options

- PC control console with free PCI plug-ins (for use by external PCI hardware)
- Safety light curtain
- Milling and engraving spindles
- SK11/SK20 automatic tool change stations
- Minimum quantity lubrication or CoolMin cooling system
- Vacuum clamping benches
- Suction device
- 4th axis e. g. RDH series installation
- Version without hood
- Maximum 6 interpolated axes + 6 handling axes
- Portal gap 300 mm
- Pneumatic sliding door
- Closed hood attachment

Setup

- Portal: moveable, bench: fixed

Dimensioned drawings/dimensions

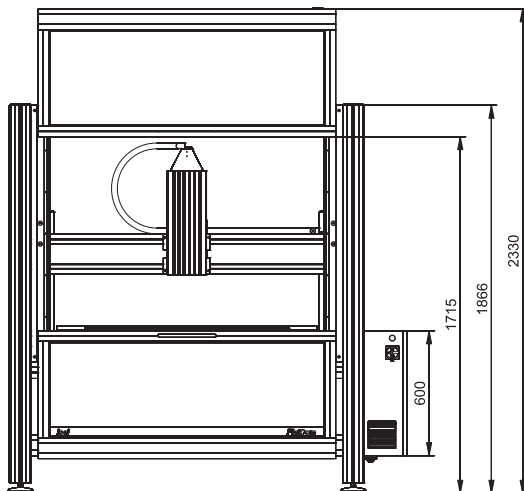

FlatCom with sub-frame and hood

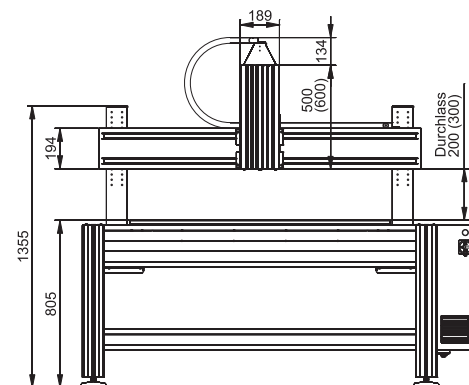

FlatCom with sub-frame, without hood

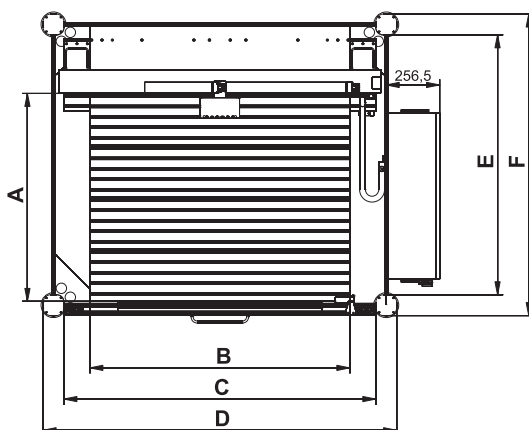

	A	B	C	D	E	F
FlatCom M20	750	750	1000	1200	950	1150
FlatCom M30	1000	750	1000	1200	1250	1450
FlatCom M40	1000	1250	1500	1700	1250	1450
FlatCom M50	1500	1250	1500	1700	1750	1950

CNC machine

with servo motor drive

FLATCom®
L series



FlatCom L with hood

Technical specification

	FLATCom® L150	FLATCom® L250
Processing areas X/Y [mm] *	1500/1700	2500/1700
Z lift [mm]	200 (optional 300, in each case without processing unit)	
Bench clamping area W × D [mm]	1600x2250	2600x2250
Z gap [mm] *	300 (optional 500, in each case without processing unit)	
Dimensions WxDxH [mm]	2216x2430x1995	3216x2430x1995
Processing speed X/Y/Z	max. 250 mm/s	
Repeat accuracy [mm]	± 0.02	
Drive motors	Servo motors	
Drive elements X/Y/Z	Recirculating ball drive, adjustable for no play	
Controller	iMD CAN controller with 3 drive controllers, expandable to 12 axes (max. 6 interpolated & 6 handling axes), PC, I/O module, safety circuit with rest state monitoring, power supply unit 48 V / 1000 W	
Operation	19" CNC control panel with touch screen, keyboard and mouse	
Weight [kg]	approx. 435	approx. 510
Software	Windows, WinRemote (optional: ProNC, isy 2.5 PLUS)	
Connection values	400 V, 16 A	
Part no.	275062 34565	275072 34565

* without mounted components on the axes.

CNC machine

with servo motor drive

FLATCom[®]
L series

General note

The choice of the ideal CNC machine for you should focus both on the clamping area for the workpiece, materials or plates to be machined and on the strategy or difficulties of the machining. In principal, all machines are perfectly suited for machining light metals, non-ferrous metals, plastics and wood. Extensive range of accessories for all our CNC machines to order (see Page 5-18 et seq.).

Options

- PC control console with free PCI plug-ins (for use by external PCI hardware)
- Safety light curtain
- Milling and engraving spindles
- SK11/SK20 automatic tool change stations
- Minimum quantity lubrication or CoolMin cooling system
- Vacuum clamping benches
- Suction device
- 4th axis e. g. RDH series installation
- Version without hood
- Maximum 6 interpolated axes + 6 handling axes
- Portal gap 300 mm
- Protective hood

Setup

- Portal: moveable, bench: fixed

Dimensioned drawings/dimensions

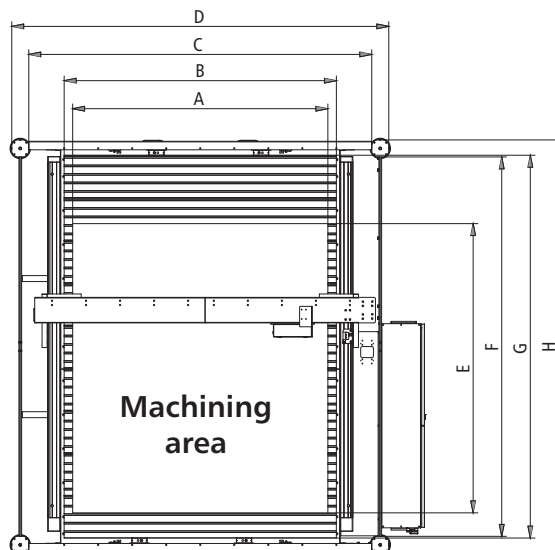
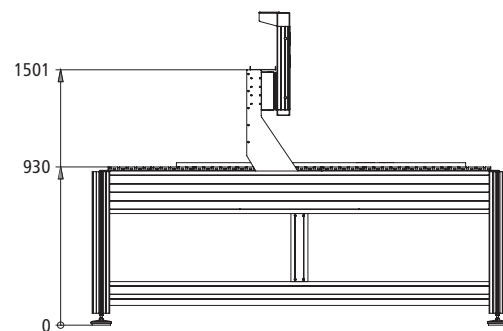
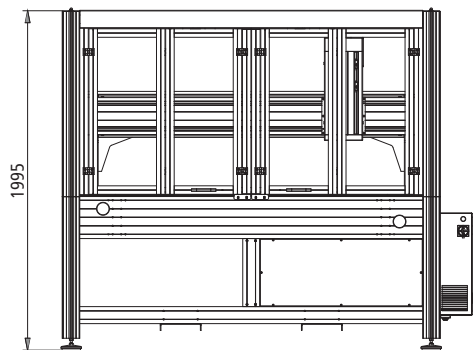

	A	B	C	D	E	F	G	H
FlatCom L 150	1500	1600	2016	2216	1700	2230	2250	2430
FlatCom L 250	2500	2600	3016	3216	1700	2230	2250	2430

CNC machine

with servo motor drive

FLATCom®
XL series



FlatCom XL with control panel

Technical specification

	<i>FLATCom®</i> 102/72	<i>FLATCom®</i> 102/112	<i>FLATCom®</i> 142/112	<i>FLATCom®</i> 142/162	<i>FLATCom®</i> 142/252
Processing areas X/Y/Z [mm] *	1020/720/220	1020/1120/220	1420/1120/220	1420/1620/220	1420/2520/220
Bench damping area W × D [mm]	1125 x 1300	1125 x 1700	1500 x 1700	1500 x 2200	1500 x 3050
Z gap [mm] *	235 (optional 435, in each case without processing unit)				
Dimensions WxDxH [mm]	2084/1584/1990	2084/1984/1990	2459/1984/1990	2459/2484/1990	2459/3384/1990
Processing speed X/Y/Z	max. 250				
Repeat accuracy [mm]	± 0.02				
Drive motors	Servo motors				
Drive elements X/Y/Z	Recirculating ball drive, adjustable for no play				
Controller	iMD CAN controller with 3 drive controllers, expandable to 12 axes (max. 6 interpolated & 6 handling axes), PC, I/O module, safety circuit with rest state monitoring, power supply unit 48V/1000 W				
Operation	19" CNC control panel with touch screen, keyboard and mouse				
Weight [kg]	approx. 550	approx. 600	approx. 700	approx. 800	approx. 1000
Software	Windows, WinRemote (optional: ProNC, isy CAD-CAM)				
Connection values	400 V, 16 A				
Part no.	274552 0013	274553 0013	274554 0013	274555 0013	274556 0013

* without mounted components on the axes.

CNC machine

with servo motor drive

FLATCom®
XL series

General note

The choice of the ideal CNC machine for you should focus both on the clamping area for the workpiece, materials or plates to be machined and on the strategy or difficulties of the machining. In principal, all machines are perfectly suited for machining light metals, non-ferrous metals, plastics and wood. Extensive range of accessories for all our CNC machines to order. (see page 5-18 et seq.)

Options

- PC control console with free PCI plug-ins (for use by external PCI hardware)
- Safety light curtain
- Milling and engraving spindles
- SK11/SK20 automatic tool change stations
- Minimum quantity lubrication or CoolMin cooling system
- Vacuum clamping benches
- Suction device
- 4th axis e. g. RDH series installation
- Version without hood
- Maximum 6 interpolated axes + 6 handling axes
- Portal gap 300 mm
- closed hood attachment

Setup

- Portal: moveable, bench: fixed

Dimensioned drawings/dimensions

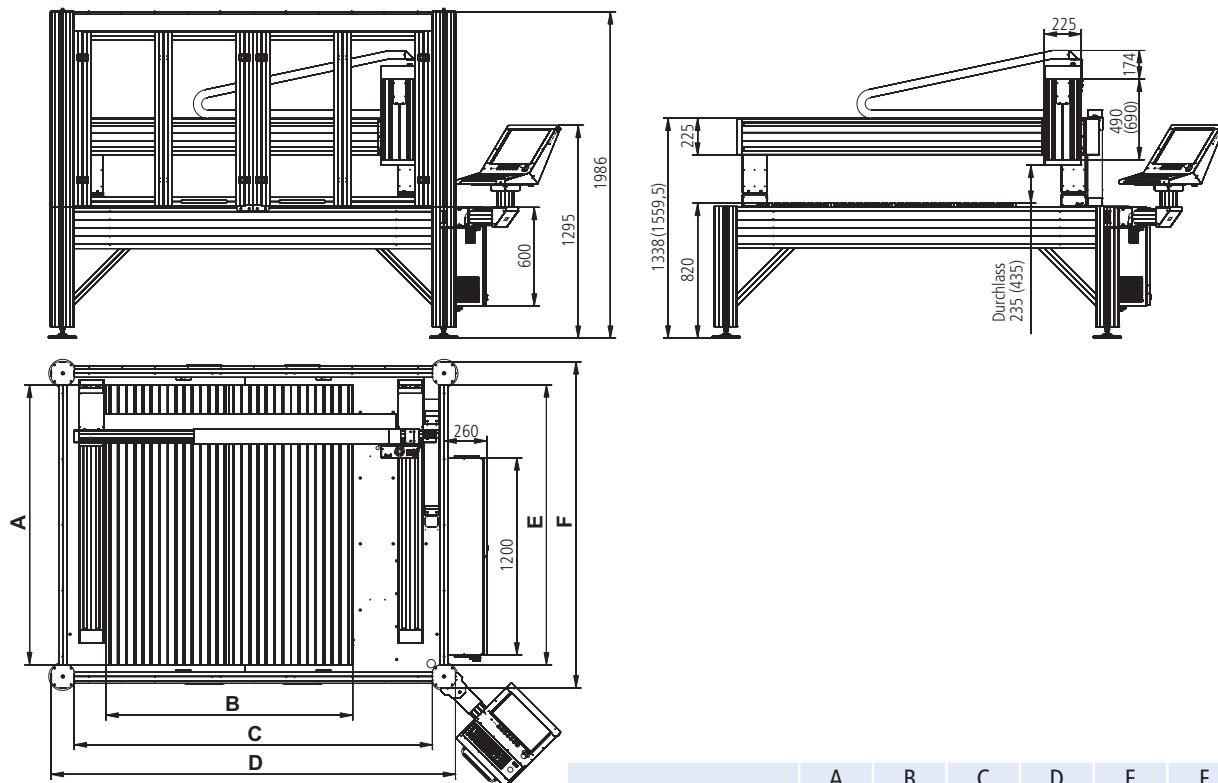

	A	B	C	D	E	F
FlatCom XL 102/72	1300	1125	1804	2084	1304	1584
FlatCom XL 102/112	1700	1125	1804	2084	1704	1984
FlatCom XL 142/112	1700	1500	2179	2459	1704	1984
FlatCom XL 142/162	2200	1500	2179	2459	2204	2484
FlatCom XL 142/252	3050	1500	2179	2459	3100	3380

Flat bed units



Flat bed unit with Z axis

General note

Flatbed units as defined in the machine guidelines as incomplete machines according to the modular system with processing paths of 250 to 1250 mm. Step motors (MS200HT), set for no-play, are used as spindle drives. Recirculating ball drives with a repeatability of ± 0.02 mm (positioning reproducibility) are used. The linear guides used are the isel double track feeds, proven over many years, with no-play pre-stressed linear ball bearings and recirculating ball spindles with a repeatability of ± 0.02 mm. All units are equipped with two limit switches per spindle. The machining and positioning units are available in a number of versions and are characterised by smooth running and high process speeds. The use of high quality aluminium components with flat-milled surfaces achieves low weight and high accuracy. isel X/Y/Z units are the ideal basis for setting up machines and systems for fitting and assembling, pressing and engraving, drilling and milling, milling and screwing, shaping and modelling, bonding and casting, soldering and welding, measuring and checking, sawing and cutting, etc..

Dimensioned drawings

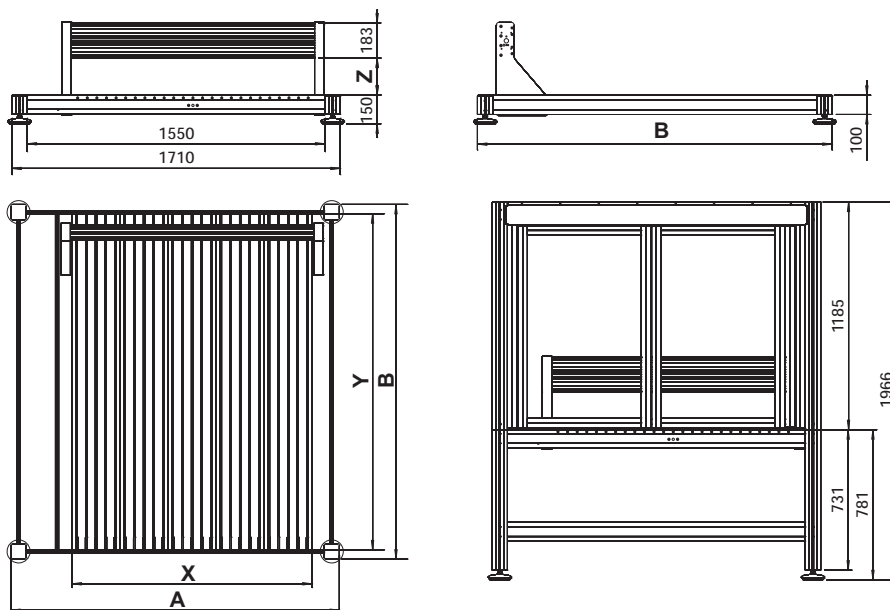

Flat bed units

X/Y flatbed units FB2

Part no.	Chassis A × B (mm)	Clamping surface X × Y (mm)	process travel X × Y (mm)	Z gap (mm)
246203M	1210 x 946	750 x 850	530 x 500	190
246203 2040M	1210 x 1196	750 x 1100	530 x 750	
246203 2054M	1210 x 1446	750 x 1350	530 x 1000	
246203 2067M	1460 x 1446	1000 x 1350	780 x 850	
246203 2130M	1710 x 1846	1250 x 1750	1030 x 1250	

All flatbed units are fitted with **16 x 4 mm recirculating ball** drives as standard



Z axes for flatbed units

Part no.	Lift (mm)	
230514M	75	with magnet brake 24 V
230514 0400M	160	with magnet brake 24 V

Underframes

Part no.	suitable for flatbed unit With clamping surface:
248500 0027	750 x 850
248500 0040	750 x 1100
248500 0054	750 x 1350
248500 0067	1000 x 1350
248500 0130	1250 x 1750

Accessories

Part no.	
219200 0001	Energy guidance chain

Software

Part no.	
Z11 - 333 500 Z13 - 337 030	ProNC software isy-CAM 2.5 Plus

Options

- Appropriate Controller (e.g.: iMC-S8)
- Software modules for operating in CAM, CNC and SPS applications
- Frame
- Housing
- Spindle motors (see pages 5-18 et seq.)
- Gap: 300 and 500 mm respectively



Housings

Part no.	suitable for flatbed units with clamping surface:
248200 0000	750 x 850
248200 2040	750 x 1100
248200 2054	750 x 1350
248200 2067	1000 x 1350
248200 2130	1250 x 1750

Introduction

When developing our spindle motors, our main emphasis was on functionality, quality, and the optimum price structure. Our spindle motors are also particularly easy to maintain. The particularly slim lines and square housing cross-section allow installation in rows with minimum separation.

Our approach to electrical construction is to use an AC short circuit rotor with 2-pole windings in our motors, designed to DIN EN 60034. The insulation of the windings is produced according to heat class F. The motors are dynamically balanced to very fine tolerances, so that good running properties are achieved even at high speeds. In all, they cover a range of speeds from 3,000 to 30,000 rpm. All spindle motors are produced entirely in Germany, meet at least the criteria for IP54 protection class and are therefore approved even for areas where wood dust is present. In our product portfolio, in addition to spindle motors, you'll find all the leads you will need in various lengths and preset, reliable frequency converters for connecting to the controller. By integrating development, production, sales and service under one roof, we have very short procedures and have our own repair service which operates year-round, unlike many of our competitors. An extensive range of accessories, such as vacuum cleaning systems, minimum amount greasing systems, collets, SK housings, tool changers and our unique, patented Coolmin system for optimum and economical tool cooling, without residues, round off our product portfolio.



ISA 500 with manual tool changer	5-19
ISA 750 with manual tool changer	5-20
ISA 1500 with manual tool changer	5-21
ISA 1500 L with manual tool changer	5-22
ISA 900 with automatic tool changer	5-23
ISA 2200 with automatic tool changer	5-24
ISA 3600 with automatic tool changer	5-25
ISA 1500 W with automatic tool changer	5-26
Universal milling spindles UFM 500 /1050 Engraving spindle	5-27
CoolMin tool cooling system	5-28
SK 11/20/30 tool change station	5-30
Frequency converter, length measuring sensor, vacuum cleaning, motor leads	5-31
Overview of collets and tool holders	5-32
6-axis robots	5-33

Spindle motor

with manual tool changer

iSA 500



Technical specification

Description		iSA 500
Torque at rated speed 18,000 rpm	[Nm]	0.28
Speed	[rpm]	5,000 to 30,000
Cut-off frequency	[Hz]	300
Number of poles		2
Rated voltage	[V]	230
Rated current	[A]	2.6
cos ϕ		0.75
S 6 = 40% rated output	[kW]	0.5
Concentricity	[mm]	0.01
Weight	[kg]	2.8

Features

- Robust 2-pole AC motor (asynchronous motor)
- Square shape, protection class IP54, isolation class F
- Cast bearing apron A-side, aluminium extrusion B-side
- Motor shaft to take ER 11 collets
- Rated output 0.5 kW (S6-40% operation)
- Speed range 5,000 rpm. - 30,000 rpm.
- Manual tool change
- M23 plug connection
- incl. ER 11 collet, \varnothing 6 mm
- Clamping range \varnothing 1 mm – \varnothing 7 mm
- Intrinsic ventilation B-side
- Controlled by Frequency converter
- Spindle bearing: 2 bearings A-side
1 bearing B-side
- Optional:
 - CoolMin® (internal and external)
 - Frequency converter
 - Various collets, mounting plates, lead lengths
 - Suction device

Ordering information

iSA 500 spindle motor
Part no.: **477004 3130**

iSA 500 spindle motor
with converter and lead (8m)
Part no.: **310704 1611**

iSA 500 spindle motor with CoolMin®
Part no.: **477004 5130**

iSA 500 spindle motor with converter,
lead (8 m) and CoolMin®
Part no.: **310704 1631**

LES 5 mounting plate
Part no.: **277014**

LES 6 / FB 2 mounting plate
Part no.: **277028 0008 / 277013**

ICP/ICV mounting plate
Part no.: **280000 0046**

EuroMod/FlatCom mounting plate
Part no.: **277028**

- SKC 750 frequency converter
see page **5-31**
- M23 motor side leads
see page **5-31**
- Suction device for 38 mm hose
see page **5-31**
- collet set, ER11 type
see page **5-32**

Dimensioned drawings

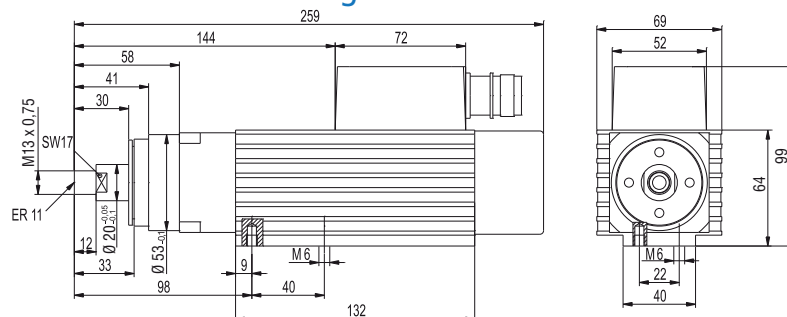

Torque curves

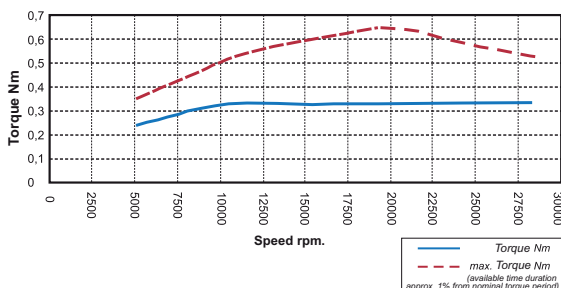

Subject to technical changes.

spindle motor

with manual tool changer



Technical specification

Description		iSA 750
Torque at rated speed 22,000 rpm	[Nm]	0.34
Speed	[rpm]	3,000 to 24,000
Cut-off frequency	[Hz]	300
Number of poles		2
Rated voltage	[V]	230
Rated current	[A]	3.4
cos ϕ		0.79
S 6 = 40% rated output	[kW]	0.75
Concentricity	[mm]	0.01
Weight	[kg]	2.6

Dimensioned drawings

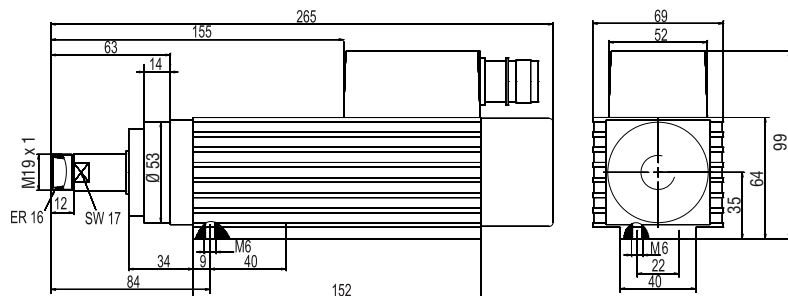

Torque curves

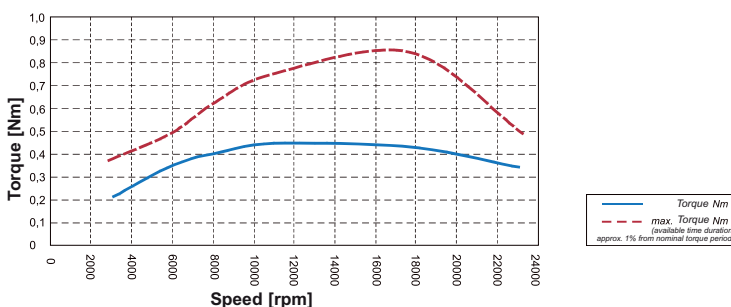

iSA 750

Features

- Robust 2-pole AC motor (asynchronous motor)
- Square shape, Protection class IP54, insulation class F
- Aluminium extrusion A and B sides
- Motor shaft to take ER 16 collets
- Rated output 0.75 kW (S6-40% operation)
- Speed range 3,000 rpm. - 24,000 rpm.
- Manual tool change
- M23 plug connection
- Incl. ER16 collet, \varnothing 6 mm
- Clamping range \varnothing 1 mm – \varnothing 10 mm
- Intrinsic ventilation B-side
- Two precision bearings
- Controlled by frequency converter
- optional:
 - CoolMin® (internal and external)
 - Frequency converter
 - Various collets, mounting plates, lead lengths
 - Suction device

Ordering information

iSA 750 spindle motor
Part no.: **477008 3124**

iSA 750 spindle motor
with converter and lead (8 m)
Part no.: **310708 1611**

iSA 750 spindle motor with CoolMin®
Part no.: **477008 5124**

iSA 750 spindle motor with converter,
lead (8 m) and CoolMin®
Part no.: **310707 1631**

LES 5 / FB 2 mounting plate
Part no.: **277014 / 277013**

LES 6 mounting plate
Part no.: **277028 0008**

ICP/ICV mounting plate
Part no.: **280000 0046**

EuroMod/FlatCom mounting plate
Part no.: **277028**

- SKC 750 frequency converter see page 5-31
- M23 motor side leads see page 5-31
- Suction device for 38 mm hose see page 5-31
- collet set, ER16 type see page 5-32

Subject to technical changes.

Spindle motor

with manual tool changer

iSA 1500



Technical specification

Description		iSA 1500
Torque at rated speed 20,000 rpm	[Nm]	0.72
Speed	[rpm]	5,000 to 20,000
Cut-off frequency	[Hz]	300
Number of poles		2
Rated voltage	[V]	230
Rated current	[A]	7
cos ϕ		0.85
S 6 = 40% rated output	[kW]	1.5
Concentricity	[mm]	0.01
Weight	[kg]	6.4

Features

- Robust 2-pole AC motor (asynchronous motor)
- Square shape, protection class IP54, insulation class F
- Cast bearing apron A and B sides
- Motor shaft to take ER 20 collets
- Rated output 1.5 kW (S6-40% operation)
- Speed range 5,000 rpm. - 20,000 rpm.
- Manual tool change
- M23 plug connection
- Incl. ER20 collet, \varnothing 6 mm
- Clamping range \varnothing 2 mm – \varnothing 13 mm
- Intrinsic ventilation B-side
- Controlled by frequency converter
- Spindle bearing: 2 bearings A-side 1 bearing B-side

optional:

- CoolMin® (internal and external)
- Frequency converter
- Various collets, mounting plates, lead lengths
- Suction device
- 4-pole motor version to order

Dimensioned drawings

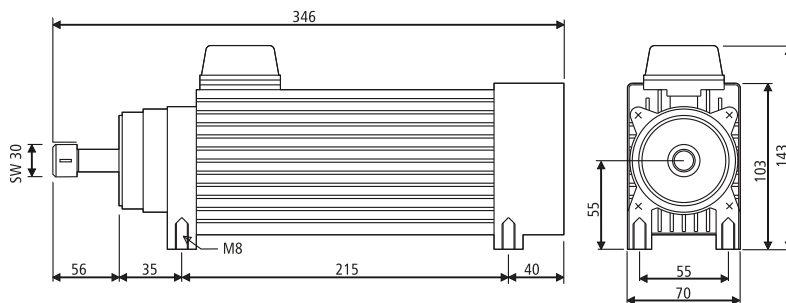

Torque curves

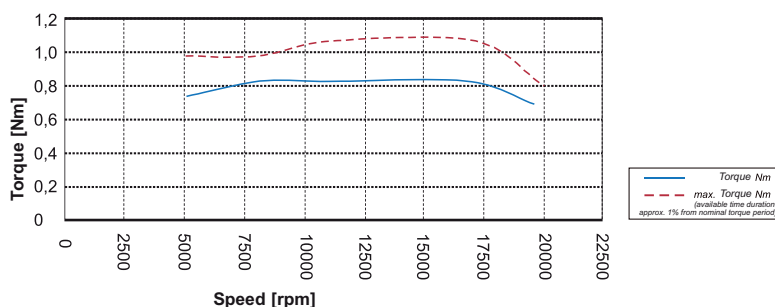

Subject to technical changes.

Ordering information

iSA 1500 spindle motor
Part no.: **477510 3120**

iSA 1500 spindle motor with converter and connecting lead (8 m)
Part no.: **310610 3614**

iSA 1500 spindle motor with CoolMin®
Part no.: **477510 5120**

iSA 1500 spindle motor with converter and CoolMin®
Part no.: **310610 3634**

LES 5 mounting plate
Part no.: **277028 0003**

EuroMod/FlatCom mounting plate
Part no.: **277028 0002**

- CoolMin® external with hose see page **5-29**
- SKC 1500 frequency converter see page **5-31**
- M23 motor side connecting leads see page **5-31**
- Suction device for 80 mm hose see page **5-31**
- collet set, ER20 type see page **5-32**

Spindle motor

with manual tool changer

iSA 1500 L



iSA 1500 L with manual tool change

Technical specification

Description		iSA 1500 L
Torque at rated speed 6,000 rpm	[Nm]	2.37
Speed range	[rpm]	2,500 to 6,000
Cut-off frequency	[Hz]	107
Number of poles		2
Rated voltage	[V]	200
Rated current	[A]	6.5
cos ϕ		0.84
Rated power (S 6 = 40% operation)	[W]	1500
Concentricity	[mm]	0.01
Weight	[kg]	10.5

Dimensioned drawings

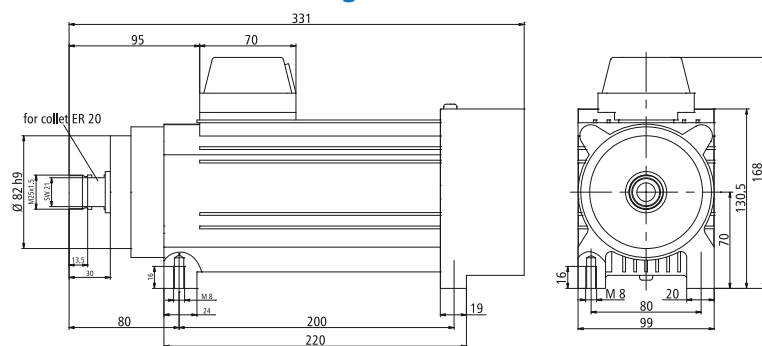

Torque curves

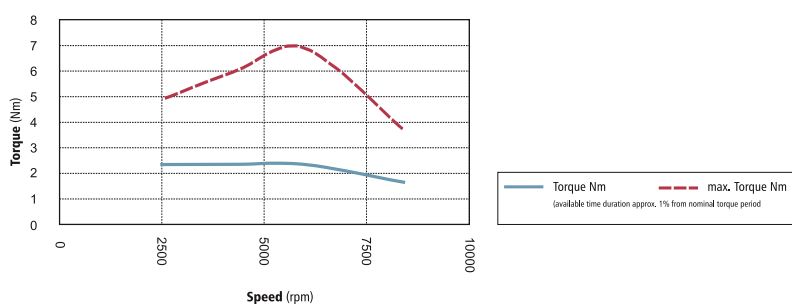

Features

- Robust 2-pole AC motor
- Protection class IP54, insulation class F
- Motor shaft to take ER 20 collets
- Cast bearing apron A and B sides
- Rated output 1.5 kW (S6-40% operation)
- Rotational speed range 2,500 rpm – 6,000 rpm
- Torque 2.37 Nm (at 6,000 rpm)
- Rated voltage 200 V
- Manual tool change
- Clamping range \varnothing 2 mm – \varnothing 13 mm
- Intrinsic ventilation B-side
- Controlled by frequency converter
- Spindle bearing:
 - A-side (milling side) double,
 - B-side (ventilation side) single
- Concentricity: 0.01 mm
- Weight: 10.5 kg
- Optional:
 - CoolMin® Tool and material cooling, external
 - Frequency converter
 - collets

Ordering information

iSA 1500 L spindle motor with collet ER 20 (6 mm), clamping key ER 20, jaw key SW 22, Interconnectron connection
Part no.: **477510 3106**

iSA 1500 L spindle motor with converter with collet ER 20 (6 mm), clamping key ER 20, jaw key SW 22, Interconnectron connection
Connecting leads 8 m
Part no.: **310610 3615**

CoolMin® external
Part no.: **239011 0119**

Suction device for EuroMod / FlatCom prepared for 38 mm diameter hose
Part no.: **239012 0001**

Clamping set ER 20
2.0 / 3.0 / 4.0 / 5.0 / 6.0 / 7.0 / 8.0 / 9.0 / 10.0 / 11.0 / 12.0 / 13.0 mm
Part no.: **239172 0001**

Mounting plate isel System (Z axis)
EuroMod / FlatCom (LES 21)
Part no.: **277028 0011**

Mounting plate isel System (Z axis)
Linear unit LES 5
Part no.: **277028 0005**

Subject to technical changes.

Spindle motor

with automatic tool changer

iSA 900



iSA 900 with automatic tool change

Features

- Robust 2-pole AC motor (asynchronous motor)
- Square shape, Protection class IP55, insulation class F
- Cast bearing apron A and B sides
- Rated output 0.9 kW (S6-40% operation)
- Speed range 6,000 rpm. - 24,000 rpm.
- Automatic tool change with SK 11 tool holder and ER 11 collet, Ø 6 mm
- M23 plug connection
- Clamping range Ø 1 mm – Ø 7 mm
- Separately driven fan B-side
- Controlled by frequency converter
- Two precision bearings
- SK 11 tool changer, pneumatic (7.5 bars)
- **Optional:**
 - CoolMin® (external)
 - Frequency converter
 - Tool changing station
 - Various collets, mounting plates, lead lengths

Technical specification

Description		iSA 900
Torque at rated speed 18,000 rpm	[Nm]	0.37
Speed	[rpm]	6,000 to 24,000
Cut-off frequency	[Hz]	400
Number of poles		2
Rated voltage	[V]	230
Rated current	[A]	3.25
cos φ		0.84
S 6 = 40% rated output	[kW]	0.9
Concentricity	[mm]	0.01
Weight	[kg]	5.8

Dimensioned drawings

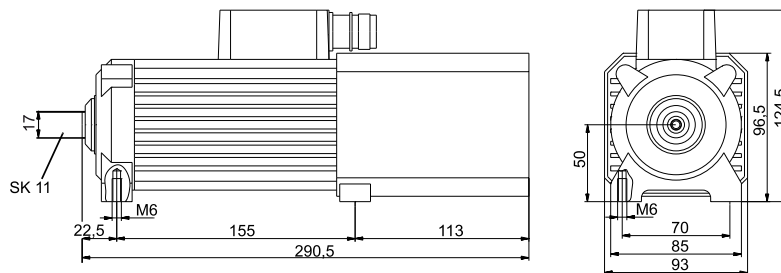

Torque curves

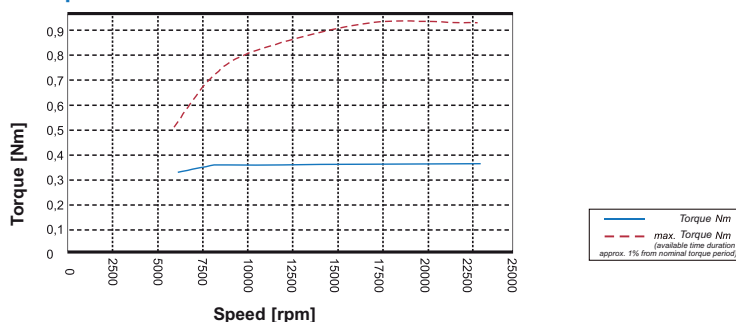

Subject to technical changes.

Ordering information

iSA 900 spindle motor
Part no.: **477009 3324**

iSA 900 spindle motor
with converter and lead (8m)
Part no.: **310709 3612**

LES 5/EuroMod/FlatCom mounting plate
Part no.: **277028 0003**

- Cooling system® external with hose see pages **5-29**
- 5 × SK 11 tool change stations see pages **5-30**
- 8 × SK 11 tool change stations see pages **5-30**
- SK 11 tool holder see pages **5-30**
- SKC 750 frequency converter see pages **5-31**
- M23 motor side connecting leads see pages **5-31**
- collet set, ER11 type see pages **5-32**

Spindle motor

with automatic tool changer

iSA 2200



iSA 2200 with automatic tool change

iSA 2200 with CoolMin® for internal tool cooling

Technical specification

Description		iSA 2200
Torque at rated speed 18,000 rpm.	[Nm]	1.26
Speed range	[rpm]	5,000 to 20,000
Cut-off frequency	[Hz]	280
Number of poles		2
Rated voltage	[V]	3 x 230
Rated current	[A]	7.6
cos ϕ		0.84
Rated power (S 6 = 40% operation)	[W]	2.2
Concentricity	[mm]	0.01
Weight	[kg]	14.6

Dimensioned drawings

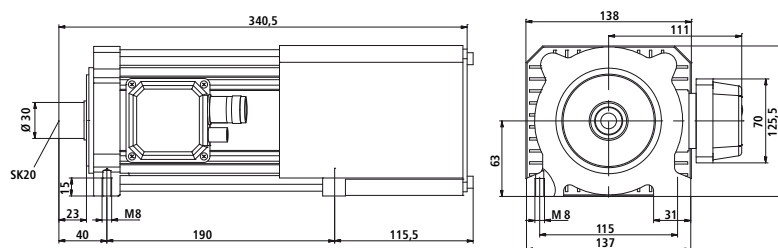

Torque curves

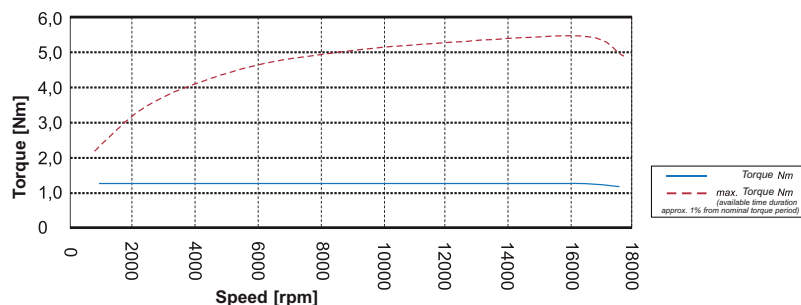

Features

- Robust 2-pole AC motor
- Protection class IP55, insulation class F
- Cast bearing apron A and B sides
- Rated output 2.2 kW (S6-40% operation)
- Rotational speed range 5,000 rpm – 20,000 rpm
- Torque 1.26 Nm (at 18,000 rpm)
- Rated voltage 3 x 230 V
- Automatic tool change
- Clamping range $\varnothing 2 - \varnothing 13$ mm
- Separately driven fan B-side
- Controlled by frequency converter
- Two precision bearings
- SK 20 tool changer, pneumatic (7.5 bars)
- Concentricity: 0.01 mm
- Weight: 14.6 kg
- **Optional:**
 - CoolMin® Tool and material cooling, external
 - CoolMin® internal with **internal tool cooling**
 - Frequency converter
 - Tool changer, collets

Ordering information

iSA 2200 spindle motor with collets ER 20 (6 mm), nut ERM 20, clamping key ER 20 M, jaw key SW 22, Interconnection connection
Part no.: **477022 3320**

iSA 2200 spindle motor as above, plus frequency converter SKC 1500, motor connecting cable 8 m
Part no.: **310722 3621**

iSA 2200 spindle motor + CoolMin® (internal) with collets ER 20 (6 mm), nut ERM 20, clamping key ER 20 M, jaw key SW 22, Interconnection connection
Part no.: **477022 5320**

iSA 2200 with converter + CoolMin® (internal) as above, plus frequency converter SKC 1500, motor connecting cable 8 m
Part no.: **310722 3631**

SK 20 tool change station 4-fold with hood
Part no.: **239011 0041**

SK 20 tool holder
Part no.: **239172 0020**

Suction device for EuroMod/FlatCom, prepared for hose $\varnothing 80$ mm, pneumatic opening
Part no.: **239012 0002**

Suction device with CoolMin® (external) for EuroMod/FlatCom, prepared for hose $\varnothing 80$ mm, pneumatic opening
Part no.: **239012 0003**

CoolMin® (external)
Part no.: **239011 0119**

Clamping set ER 20 2.0/3.0/4.0/5.0/6.0/7.0/8.0/9.0/10.0/11.0/12.0/13.0 mm
Part no.: **239172 0001**

Mounting plate isel System (Z axis)
FlatCom / EuroMod Part no.: **277028 0004**
LES 5 Part no.: **277028 0005**

Subject to technical changes.

Spindle motor

with automatic tool changer

iSA 3600



iSA 3600 with automatic tool change

Technical specification

Description		iSA 3600
Torque at rated speed 18,000 rpm	[Nm]	4.5
Speed	[rpm]	6,000 to 18,000
Cut-off frequency	[Hz]	300
Number of poles		2
Rated voltage	[V]	3 x 400
Rated current	[A]	5.4
cos ϕ		0.87
S 6 = 40% rated output	[kW]	3.6
Concentricity	[mm]	0.01
Weight	[kg]	23.0

Dimensioned drawings

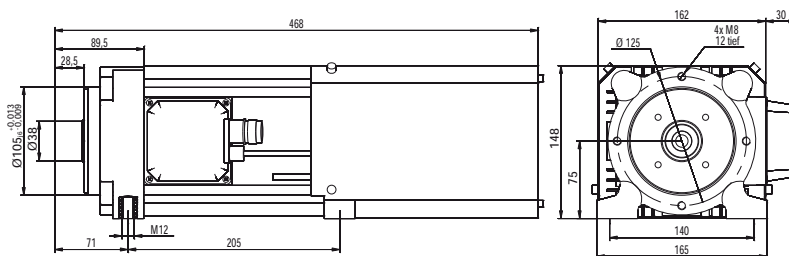

Torque curves

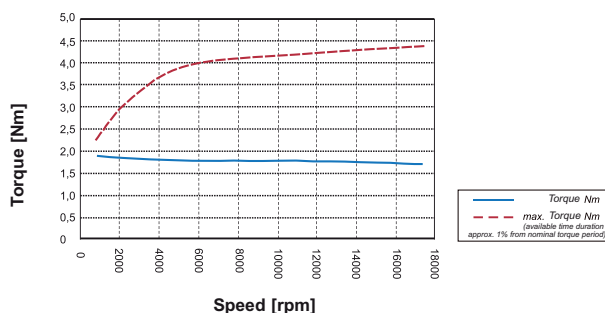

Subject to technical changes.

Features

- Robust 2-pole AC motor
- Square shape, protection class IP54, insulation class F
- Cast bearing apron A-side, aluminium extrusion B-side
- Motor shaft to take ER 32 collets
- Rated output 3.6 kW (S6-40% operation)
- Speed range 6,000 rpm. - 18,000 rpm.
- Automatic tool changer with SK 30 tool holder and ER 32 collet, \varnothing 6 mm
- Clamping range \varnothing 3 mm – \varnothing 20 mm
- Intrinsic ventilation B-side
- Two precision bearings
- Controlled by frequency converter
- **Optional:**
 - CoolMin® (external)
 - Frequency converter
 - Tool changing station
 - Various collets, mounting plates and lead lengths

Ordering information

iSA 3600 spindle motor
Part no.: **477822 3600**

iSA 3600 spindle motor with converter and connecting lead (8 m)
Part no.: **310736 3615**

LES 5 mounting plates
Part no.: **277028 0009**

- CoolMin® external with hose see page **5-29**
- 4 x SK 30 tool change stations see page **5-30**
- 5 x SK 30 tool change stations see page **5-30**
- SK 30 tool holder see page **5-30**
- SKC 4000 frequency converter see page **5-31**
- M23 motor side leads see page **5-31**
- collet set, type ER 32 see page **5-32**

Spindle motor

for high rotational speeds, with **automatic tool changer**

iSA 1500 W



Features

- Precision angular ball bearings
- Automatic tool change with SK 20 tool holder and ER 20 collets, \varnothing 6 mm
- Clamping range \varnothing 2 mm - 13 mm
- Pneumatic tool change (7.5 bar)
- Controlled by frequency converter
- Balancing to EN/ISO standards
- IP54 protection class

- **Optional**
 - Tool changing station
 - Various collets

Technical specification

Description		
Max. torque	[Nm]	0.47
Max. Speed	[rpm]	40,000 (666 Hz)
Cut-off frequency	[Hz]	500 (30,000 rpm)
Number of poles		2
Rated voltage	[V]	3 x 230
tool holder	[ISO]	20
cos ϕ		0.8
Max. Output power (S 1)	[kW]	1.75
Concentricity	[mm]	under 0.01 or under 0.005 on request
Weight	[kg]	10

Ordering information

iSA 1500 W spindle motor
Part no. **477015 3340**

iSA 1500 W spindle motor with converter
Part no. **310715 3612**

- SKC 1500 frequency converter
see pages 5-31
- collet set, ER20 type
see pages 5-32

Dimensioned drawings

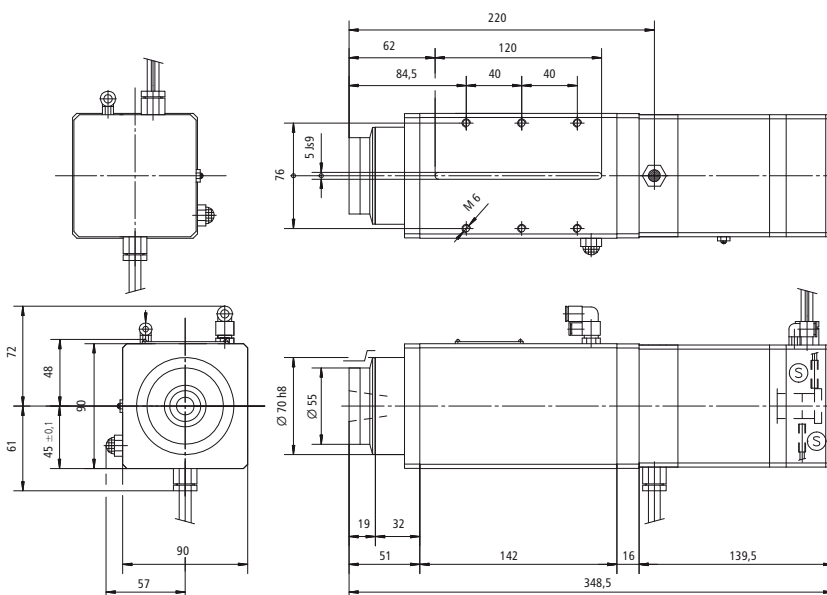

Torque curves

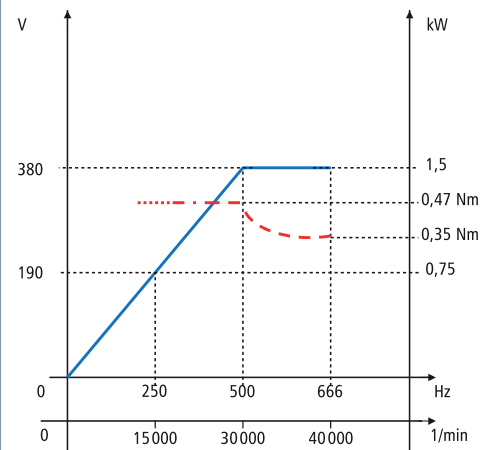

Subject to technical changes.

Universal milling and engraving spindles UFM 500/1050



UFM 1050

UFM 500

Technical specification

	Part no.	Load speed rpm	Voltage V	Efficiency %	Power consumption W	Power output W	Torque Nm
UFM 500	420003 0500	22.600	230	68	500	345	0.14
UFM 500-11	420003 0501	22.600	115	68	500	345	0.14
UFM 1050	420003 1050	21000	230	71	1050	720	0.32
UFM 1050-11	420003 1051	21.000	115	71	1050	720	0.32

Dimensioned drawings

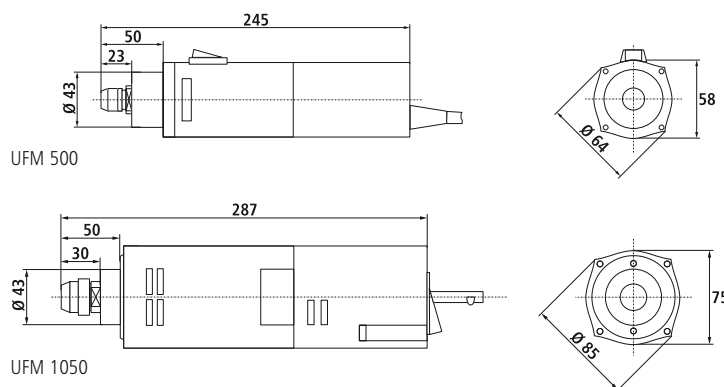

UFM 500

UFM 1050

Features

- Load-independent working speed with Tacho control electronics
- Smooth start for no-backlash acceleration to rated speed
- Blocking protection
- Protective isolation
- PTC thermal monitoring
- Rated output 345 W/720 W
- Speed range 11,000 to 25,000 rpm
- Torque 0.14 Nm (at 22,600/21,000 rpm)
- Rated voltage 230 V
- Collar
- Clamping range $\varnothing 1 - \varnothing 6.35 / 8$ mm
- Speed control
- Rigid double ball bearing
- Weight: 1.9 / 2.1 kg

UFM 500

- Input power **500 W**
- Output power **345 W**
- Torque **0.14 Nm**

UFM 1050

- Power consumption **1050 W**
- Output power **720 W**
- Torque **0.32 Nm**

Clamping blocks

Clamping blocks $\varnothing 43$ mm	Part no.
Ra 100 and Ra 150 mm fixings	290 902
Ra 100 mm fixing	290 903
Ra 125 mm fixing	290 904

Collets

collet sets	Part no.
for UFM 500 ($\varnothing 1.0 - 6.35$ mm)	239110
for UFM 1050 ($\varnothing 1.0 - 8.0$ mm)	239112 0000

Clamping nut

Clamping nut	Part no.
for UFM 500	239 111
for UFM 1050	239 112

Carbon brushes

Carbon brushes, VE = 2 units.	Part no.
for UFM 500	420 003 9000
for UFM 1050	420 003 9001

Tool cooling system

COOLMin

Functional principle

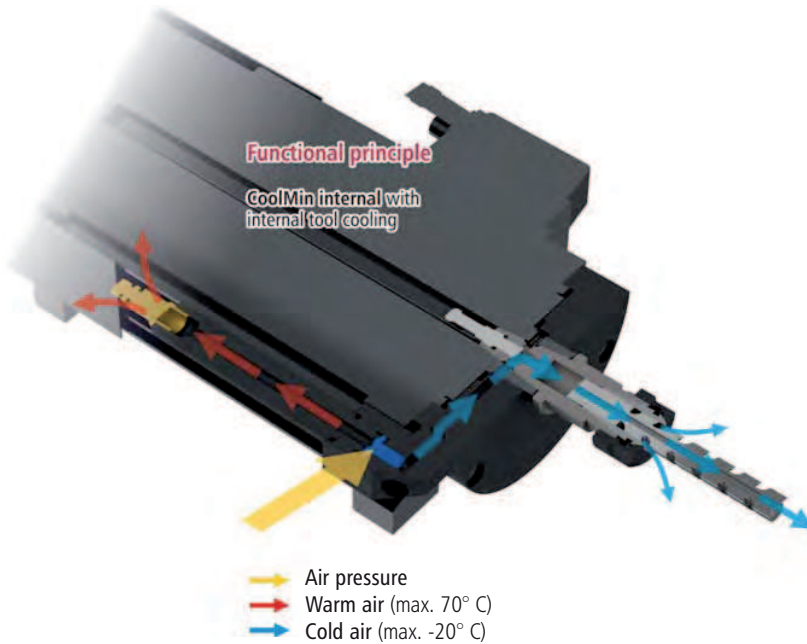

- 1 Spindle motor
- 2 Temperature controller
- 3 Hot air exhaust
- 4 Vortex nozzle with cold air exhaust
- 5 Compressed air feed
- 6 Cold air blower in synthetic material
- 7 Tool holder for internal cooling
- 8 Milling cutter for internal cooling



Tool and material cooling

Dry cutting is today the first choice for many machining tasks.

Hitherto, materials, tool wear and surface finish have often necessitated cooling with appropriate coolants / greases. This always means moisture. Even minimal moisture spray cooling causes unwanted effects such as the build-up of dirt and the adhesion of swarf to the cutting tool or to the working surface and can lead to the deterioration of the material surface structure, depending on the material being machined.

Our patented cooling method ensures adequate tool and surface cooling and reduces such effects to negligible levels. This keeps the swarf dry and, depending on the material, easy to remove by either blowing or vacuuming. Surfaces are therefore protected and, as a result of direct tool cooling, tool life is significantly increased (also suitable for tools with integrated cooling).

The main component of our cooling method is a cold air nozzle, which operates on the eddy current principle and separates warm air from cold.

The system is powered by air pressure alone (6 to 10 bar).

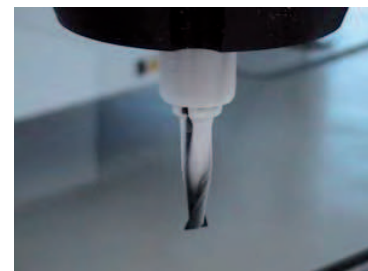

Tool, cooled by CoolMin internal

Subject to technical changes.

Tool cooling system

COOLMin

Functional principle

CoolMin external

CoolMin internal without tool cooling system

- 1 Compressed air feed
- 2 Flexible mating hose
- 3 Spindle motor
- 4 Temperature controller
- 5 Hot air exhaust
- 6 Vortex nozzle with Cold air exhaust
- 7 Cold air supply in synthetic material
- 8 Collet



Diagram:
CoolMin external with mating hose



Diagram:
CoolMin internal

Technical specification

Compressed air feed	6 – 10 bar
Cold air exhaust	up to max. -25° C
Hot air exhaust	up to max. 70° C
Air consumption	approx. 150 l/min.

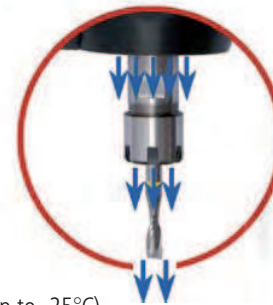

Diagram:
Optimum cold air flow (up to -25°C) for tool cooling and chip evacuation

Ordering information

Description		Part number
CoolMin external	with mating hose, incl. servicing kit and shut-off tap (manual)	239011 0119
CoolMin external	incl. servicing kit and electrically-powered valve	239011 0117
CoolMin internal		see individual motors

Subject to technical changes.

Tool change stations

SK 11 / 20 / 30

4× linear changers
for SK 20

5x linear
changer for
SK 11

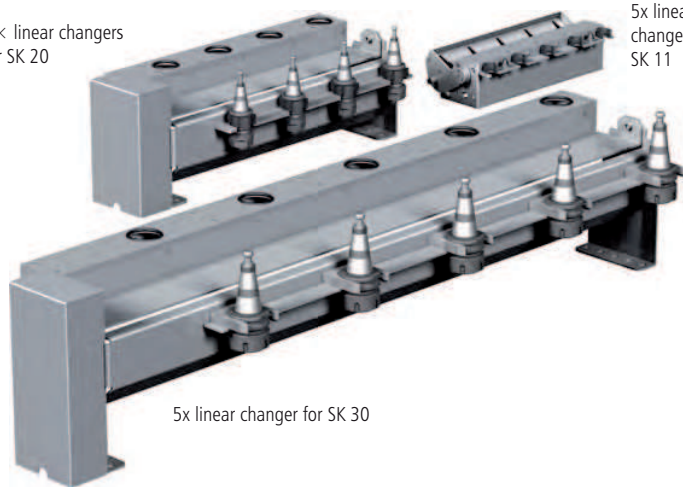

5x linear changer for SK 30

Features

- Simple, functional tool changer for SK11, SK20 and SK30
- Pneumatic rotary cylinder and end position monitoring for safe changing
- Control via 5/2-way valve with integration in the safety circuit
- Low-maintenance, stainless steel design (powder-coated aluminium)
- Variable positioning on the machine bench

Dimensioned drawings

SK 11 tool changer

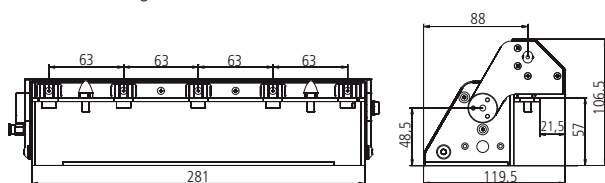

SK 20 tool changer

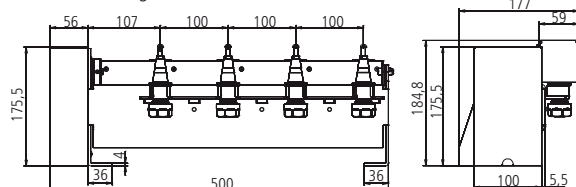

SK 30 tool changer

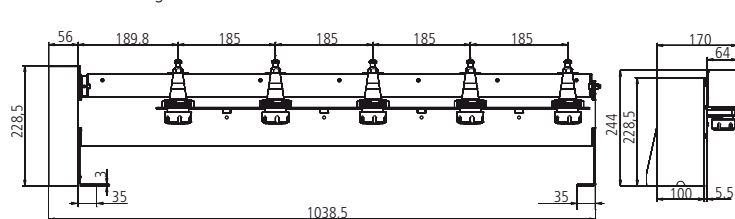

Ordering information

SK 11 tool change station ... for iSA 900

5×, without hood + pneumatics
Part no.: **239011 0053**

8×, with hood + pneumatics
Part no.: **239011 0083**

Tool holders

SK 11 for collets, type ER 11
Part no.: **239111 0001**

SK 20 tool change station ...for iSA 2200

4×, with hood + pneumatics
Part no.: **239011 0041**

5×, without hood + pneumatics
Part no.: **239011 0050**

10×, with hood + pneumatics
Part no.: **239011 0100** (to order)

Tool holders

SK 20 for collets, type ER 20
Part no.: **239172 0020**

SK 30 tool change station ...for iSA 3600

4×, with hood + pneumatics
Part no.: **239011 0045**

5×, without hood + pneumatics
Part no.: **239011 0055**

Tool holders

SK 30 for collets, type ER 32
Part no.: **239130**

collets ER 11, ER 20, ER 30
see page **5-32**

Subject to technical changes.

Frequency converter, motor leads and Vacuum cleaning

Frequency converters



SKC 750 frequency converter, suitable for iSA 500, iSA 750 + iSA 900
Part no.: **311707 6000**

SKC 1500 frequency converter, suitable for iSA 1500 + iSA 2200
Part no.: **311715 6000**

SKC 4000 frequency converter, suitable for iSA 3600
Part no.: **311740 6500**

- Compact, pulse width modulated equipment in three output classes
- Input voltage, 230 V AC, single phase (SKC 750/1500) or 400 V AC, three phase (SKC 4000)
- Three phase, vector controlled control voltage frequency 0...1500 Hz
- Fast spindle braking with highly stressed, integrated brake resistance in the sub-frame
- Turn-off EMC filter
- Programmable inputs and outputs, relay output
- User-friendly control unit for configuring spindles
- 95 operating and display parameters for both simple and demanding applications (e. g. spindle energy sink in no load)
- Protection class: IP 20
- Control types: SPS; 0...10 V; 0...20 mA; with operating unit; CAN Bus (additional module required)
- Approved: CE; C-Tick; UL

Length measurement button and motor leads



Length measuring sensor for measuring tool lengths
Part no.: **239099 0001**

- 8-wire (3x 0.75 mm² + 1x PE + 2x(2 × 0.34 mm²))
- Drag chain compatible
- External braiding and separately shielded pairs
- Pre-fabricated



Motor side - M23 plug
Converter side - wire end bushings
Part no.: **392306 0300** (3 m)
Part no.: **392306 0500** (5 m)
Part no.: **392306 0800** (8 m)

Motor side - direct connection
Converter side - wire end bushings
Part no.: **392301 0300** (3 m)
Part no.: **392301 0500** (5 m)
Part no.: **392301 0800** (8 m)

Vacuum cleaning

... for iSA 500 + iSA 750 spindles

- prepared for hose 38 mm
- manual opening

Part no.: **239012 0000**

... for iSA 900 spindle

- prepared for hose 50 mm
- automatic opening

Part no.: **239012 0004**

... for iSA 1500 spindle

- prepared for hose 80 mm
- manual opening

Part no.: **239012 0001**

... for iSA 2200 spindle

- prepared for hose 80 mm
- automatic opening

Part no.: **239012 0002**

... for iSA 2200 spindle with external CoolMin

- prepared for hose 80 mm
- automatic opening

Part no.: **239012 0002**

Dust cover closed

Air hose inside diameter 80 mm



Dust cover open

Subject to technical changes.

Overview of collets and tool holders

tool holders



SK 11 SK 20 SK 30

SK 11 for collets, type ER 11
Part no.: **239111 0001**

SK 20 for collets, type ER 20
Part no.: **239172 0020**

SK 30 for collets, type ER 32
Part no.: **239130**

The following collets are also able to clamp shafts reduced in diameter by 1.0 mm:

Collets type ER 11

for iSA 500 and iSA 900

Ø (mm)	Part no.
1.0	239170 1000
1.5	239170 1500
2.0	239170 2000
2.5	239170 2500
3.0	239170 3000
3.5	239170 3500
4.0	239170 4000
4.5	239170 4500
5.0	239170 5000
5.5	239170 5500
6.0	239170 6000
6.5	239170 6500
7.0	239170 7000

Collet set

for spindle motor	Type	Ø (mm)	Part no.
iSA 500/iSA 900	ER 11	1.0 - 7.0	239170 0001

Clamping nuts

Type	Part no.
ERM 11	239170
ERM 16	239171
ERM 20	239172



ER 11



ER 16



ER 20

The following collets are also able to clamp shafts reduced in diameter by 0.5 mm:

Collets type ER 16

for iSA 750

Ø (mm)	Part no.
1.0	239171 1000
2.0	239171 2000
3.0	239171 3000
4.0	239171 4000
5.0	239171 5000
6.0	239171 6000
7.0	239171 7000
8.0	239171 8000
9.0	239171 9000
10.0	239171 0100

Collets type ER 20

for iSA 1500 and iSA 2200

Ø (mm)	Part no.
2.0	239172 2000
3.0	239172 3000
4.0	239172 4000
5.0	239172 5000
6.0	239172 6000
7.0	239172 7000
8.0	239172 8000
10.0	239172 0100
11.0	239172 0110
12.0	239172 0120
13.0	239172 0130

Collets type ER 32

for iSA 3600

Ø (mm)	Part no.
3.0	239130 3000
4.0	239130 4000
5.0	239130 5000
6.0	239130 6000
7.0	239130 7000
8.0	239130 8000
9.0	239130 9000
10.0	239130 0100
11.0	239130 0110
12.0	239130 0120
13.0	239130 0130
14.0	239130 0140
15.0	239130 0150
16.0	239130 0160
17.0	239130 0170
18.0	239130 0180
19.0	239130 0190
20.0	239130 0200

Collet sets

for spindle motor	Type	Ø (mm)	Part no.
iSA 750	ER 16	1.0 - 10	239171 0001
iSA 1500 / iSA 2200	ER 20	2.0 - 13	239172 0001
iSA 3600	ER 32	3.0 - 20	239130 0000

Vacuum clamping plates

VAKUFIT[®]

systems

Sample diagram



Multiple connections for high volume flow and optimal vacuum distribution.

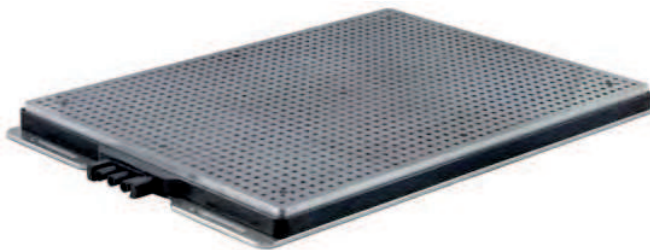

All our vacuum plates can be arranged to fit together to cover large areas.

Part number	Description	DIN	Clamping surface
216601 0017	VT 2115	A5	210 x 150 mm
216601 0018	VT 3021	A4	300 x 210 mm
216601 0019	VT 4230	A3	420 x 300 mm
216601 0020	VT 6042	A2	600 x 420 mm

216601 0028	Rotary vane pump (6.0 m ³ /h) for DIN A4 und A5
216601 0030	Rotary vane pump (10.0 m ³ /h) for DIN A4 und A5

216600 0027	Servicing kit for rotary vane pump 6.0 m ³ /h
216600 0028	Servicing kit for rotary vane pump 10.0 m ³ /h

216601 0010	Connection set vacuum plate to rotary vane pump
616601	Rubber matting for vacuum plates

Subject to technical changes.

VakuFit - L

The raster plates for the vacuum clamping makes little demand on the vacuum pump. The plates are almost totally warp free and the material is therefore suitable for engraving operations when clamped.

In contrast to other vacuum clamping methods, surfaces can be milled over large areas without problem, with parts remaining securely clamped.

Material stops can be easily effected by inserting 5 mm dowelling pins into the raster plate holes. The board rubber matting is a consumable with a variety of uses. In addition to our standard plates, we offer customised variants and complete plate packages for special applications.

Note

Retaining force is proportional to the area covered, the coefficient of friction and the differential pressure.

In order to increase the coefficient of friction, rubber matting is included within the scope of delivery.

Scope of delivery

- 1x connection adapter
- 1x screw key 68 mm
- 1x rubber matting for holes
- 1x rubber matting for covering unused holes
- Operating instructions